

AS 61869.14:2021



Instrument transformers

Part 14: Additional requirements for current transformers for DC applications (IEC 61869-14:2018 (ED 1.0) MOD)



AS 61869.14:2021

This Australian Standard® was prepared by EL-013, Measurement And Protection Transformers. It was approved on behalf of the Council of Standards Australia on 3 February 2021.

This Standard was published on 26 February 2021.

The following are represented on Committee EL-013:

- Australian Industry Group
- Energy Networks Australia
- Engineers Australia
- National Measurement Institute
- University of South Australia

This Standard was issued in draft form for comment as DR AS 61869.14:2021.

Keeping Standards up-to-date

Ensure you have the latest versions of our publications and keep up-to-date about Amendments, Rulings, Withdrawals, and new projects by visiting:

www.standards.org.au

ISBN 978 1 76113 229 2

Instrument transformers

Part 14: Additional requirements for current transformers for DC applications (IEC 61869-14:2018 (ED 1.0) MOD)

First published as AS 61869.14:2021.



© IEC 2021 — All rights reserved
© Standards Australia Limited 2021

All rights are reserved. No part of this work may be reproduced or copied in any form or by any means, electronic or mechanical, including photocopying, without the written permission of either the IEC or the publisher, unless otherwise permitted under the Copyright Act 1968 (Cth). If you have any questions about IEC copyright or have an enquiry about obtaining additional rights to this publication, please see the contact details on the back cover or the contact us page of the website for further information.

Preface

This Standard was prepared by the Standards Australia Committee EL-013, Measurement and Protection Transformers.

The objective of this document is to provide all requirements specific to current transformers to be used in DC applications (DCCTs), whatever the technology used. The output signal can be analogue or digital.

It is applicable to newly manufactured current transformers used for measuring, protection and/or control applications in DC power systems with a rated voltage above 1,5 kV.

The DCCTs intended for current measurement in the transistor branch of the VSC valve (referred to as CT4a and CT4b in Figure 1403 and Table 1402) are not covered by this document.

This document is an adoption with national modifications, and has been reproduced from, IEC 61869-14:2018, *Instrument transformers — Part 14: Additional requirements for current transformers for DC applications*.

The modifications are additional requirements and are set out in [Appendices ZZ](#), which has been added at the end of the source text.

[Appendix ZZ](#) lists the variation to IEC 61869-14:2018 for the application of this document in Australia.

As this document has been reproduced from an International Standard, the following applies:

- (a) In the source text “this part of 61869” should read “this document”.
- (b) A full point substitutes for a comma when referring to a decimal marker.

Australian or Australian/New Zealand Standards that are identical adoptions of international normative references may be used interchangeably. Refer to the online catalogue for information on specific Standards.

The terms “normative” and “informative” are used in Standards to define the application of the appendices or annexes to which they apply. A “normative” appendix or annex is an integral part of a Standard, whereas an “informative” appendix or annex is only for information and guidance.

NOTES

CONTENTS

FOREWORD.....	4
INTRODUCTION.....	7
1 Scope.....	11
2 Normative references	11
3 Terms and definitions	11
5 Ratings.....	16
6 Design and construction	20
7 Tests	25
Annex 14A (informative) Equivalent thermal current in CTs for DC application.....	37
14A.1 General.....	37
14A.2 Current harmonic content.....	37
14A.3 Losses in primary conductor due to harmonic content	38
14A.4 Thermal test with AC current.....	40
Annex 14B (informative) Proposed rated insulation level applicable to current transformers for DC application.....	41
Bibliography.....	42
Figure 1401 – Example of LCC scheme	7
Figure 1402 – Typical scheme for VSC – symmetrical monopole.....	8
Figure 1403 – Typical scheme for VSC – asymmetrical monopole or bipole	9
Figure 1404 – Typical step responses of a system	14
Figure 1405 – Accuracy limits of a DCCT.....	19
Figure 1406 – Polarity reversal test profile.....	30
Figure 1407 – Measurement of the step response time	32
Figure 14A.1 – Typical waveform of current flowing in the primary conductor for LCC applications	37
Figure 14A.2 – The two terms that make up the total losses in the primary conductor.....	39
Figure 14A.3 – Additional losses in conductors due to typical current harmonics	40
Figure 14A.4 – Power-frequency losses in conductors compared to DC losses	40
Table 1401 – Current and voltage in current transformers for LCC application	8
Table 1402 – Current and voltage in current transformers for VSC application.....	10
Table 3 – Partial discharge test voltages and permissible levels	17
Table 1403 – Limits of ratio error for DCCT (classes from 0,1 to 1).....	19
Table 7 – Static withstand test loads.....	21
Table 8 – Arc fault duration and performance criteria	22
Table 1404 – Markings of terminals	23
Table 1405 – Rating plate marking for common rating plate	24
Table 1406 – Rating plate marking for each secondary converter	24
Table 1407 – Rating plate marking for auxiliary power supply	25

Table 10 – List of tests.....	26
Table 14A.1 – Typical harmonic current values (800 kV LCC)	38
Table 14B.1 – Proposed rated primary terminal insulation levels for current transformers for DC application.....	41

INTERNATIONAL ELECTROTECHNICAL COMMISSION

INSTRUMENT TRANSFORMERS –**Part 14: Additional requirements for current transformers for DC applications**

FOREWORD

- 1) The International Electrotechnical Commission (IEC) is a worldwide organization for standardization comprising all national electrotechnical committees (IEC National Committees). The object of IEC is to promote international co-operation on all questions concerning standardization in the electrical and electronic fields. To this end and in addition to other activities, IEC publishes International Standards, Technical Specifications, Technical Reports, Publicly Available Specifications (PAS) and Guides (hereafter referred to as "IEC Publication(s)"). Their preparation is entrusted to technical committees; any IEC National Committee interested in the subject dealt with may participate in this preparatory work. International, governmental and non-governmental organizations liaising with the IEC also participate in this preparation. IEC collaborates closely with the International Organization for Standardization (ISO) in accordance with conditions determined by agreement between the two organizations.
- 2) The formal decisions or agreements of IEC on technical matters express, as nearly as possible, an international consensus of opinion on the relevant subjects since each technical committee has representation from all interested IEC National Committees.
- 3) IEC Publications have the form of recommendations for international use and are accepted by IEC National Committees in that sense. While all reasonable efforts are made to ensure that the technical content of IEC Publications is accurate, IEC cannot be held responsible for the way in which they are used or for any misinterpretation by any end user.
- 4) In order to promote international uniformity, IEC National Committees undertake to apply IEC Publications transparently to the maximum extent possible in their national and regional publications. Any divergence between any IEC Publication and the corresponding national or regional publication shall be clearly indicated in the latter.
- 5) IEC itself does not provide any attestation of conformity. Independent certification bodies provide conformity assessment services and, in some areas, access to IEC marks of conformity. IEC is not responsible for any services carried out by independent certification bodies.
- 6) All users should ensure that they have the latest edition of this publication.
- 7) No liability shall attach to IEC or its directors, employees, servants or agents including individual experts and members of its technical committees and IEC National Committees for any personal injury, property damage or other damage of any nature whatsoever, whether direct or indirect, or for costs (including legal fees) and expenses arising out of the publication, use of, or reliance upon, this IEC Publication or any other IEC Publications.
- 8) Attention is drawn to the Normative references cited in this publication. Use of the referenced publications is indispensable for the correct application of this publication.
- 9) Attention is drawn to the possibility that some of the elements of this IEC Publication may be the subject of patent rights. IEC shall not be held responsible for identifying any or all such patent rights.

International Standard IEC 61869-14 has been prepared by IEC technical committee 38: Instrument transformers.

The text of this standard is based on the following documents:

FDIS	Report on voting
38/560/FDIS	38/565/RVD

Full information on the voting for the approval of this International Standard can be found in the report on voting indicated in the above table.

This document has been drafted in accordance with the ISO/IEC Directives, Part 2.

A list of all parts in the IEC 61869 series, published under the general title *Instrument transformers*, can be found on the IEC website.

This Part 14 is to be used in conjunction with, and is based on, IEC 61869-1:2007, *General requirements*, and IEC 61869-6:2016, *Additional general requirements for low-power instrument transformers* – however the reader is encouraged to use the most recent editions.

This Part 14 follows the structure of IEC 61869-1:2007 and IEC 61869-6:2016 and supplements or modifies their corresponding clauses.

When a subclause of Part 1 or Part 6 is not mentioned in this Part 14, that subclause applies. When this standard states “addition”, “modification” or “replacement”, the relevant text in Part 1 or Part 6 is to be adapted accordingly.

For additional clauses, subclauses, figures, tables, annexes or notes, the following numbering system is used:

- clauses, subclauses, tables, figures and notes that are numbered starting from 1401 are additional to those in Part 1 and Part 6;
- additional annexes are lettered 14A, 14B, etc.

An overview of the planned set of standards at the date of publication of this document is given below. The updated list of standards issued by IEC TC 38 is available at the website: www.iec.ch

PRODUCT FAMILY STANDARDS	PRODUCT STANDARD	PRODUCTS	OLD STANDARD	
61869-1 GENERAL REQUIREMENTS	61869-2	ADDITIONAL REQUIREMENTS FOR CURRENT TRANSFORMERS	60044-1 60044-6	
	61869-3	ADDITIONAL REQUIREMENTS FOR INDUCTIVE VOLTAGE TRANSFORMERS	60044-2	
	61869-4	ADDITIONAL REQUIREMENTS FOR COMBINED TRANSFORMERS	60044-3	
	61869-5	ADDITIONAL REQUIREMENTS FOR CAPACITIVE VOLTAGE TRANSFORMERS	60044-5	
	61869-6 ADDITIONAL GENERAL REQUIREMENTS FOR LOW-POWER INSTRUMENT TRANSFORMERS	61869-7	ADDITIONAL REQUIREMENTS FOR ELECTRONIC VOLTAGE TRANSFORMERS	60044-7
		61869-8	ADDITIONAL REQUIREMENTS FOR ELECTRONIC CURRENT TRANSFORMERS	60044-8
		61869-9	DIGITAL INTERFACE FOR INSTRUMENT TRANSFORMERS	
		61869-10	ADDITIONAL REQUIREMENTS FOR LOW-POWER PASSIVE CURRENT TRANSFORMERS	
		61869-11	ADDITIONAL REQUIREMENTS FOR LOW-POWER PASSIVE VOLTAGE TRANSFORMERS	60044-7
		61869-12	ADDITIONAL REQUIREMENTS FOR COMBINED ELECTRONIC INSTRUMENT TRANSFORMER OR COMBINED LOW-POWER PASSIVE TRANSFORMERS	
		61869-13	STAND ALONE MERGING UNIT	
		61869-14	ADDITIONAL REQUIREMENTS FOR CURRENT TRANSFORMERS FOR DC APPLICATIONS	
		61869-15	ADDITIONAL REQUIREMENTS FOR VOLTAGE TRANSFORMERS FOR DC APPLICATIONS	

The committee has decided that the contents of this document will remain unchanged until the stability date indicated on the IEC website under "<http://webstore.iec.ch>" in the data related to the specific document. At this date, the document will be

- reconfirmed,
- withdrawn,
- replaced by a revised edition, or
- amended.

IMPORTANT – The 'colour inside' logo on the cover page of this publication indicates that it contains colours which are considered to be useful for the correct understanding of its contents. Users should therefore print this document using a colour printer.

INTRODUCTION

General

This document applies to current transformers intended to be used in DC applications with at least one of the following functions:

- measure DC current (with significant harmonics);
- withstand DC voltage.

Depending on the position of the current transformer on the DC system, different kinds of application exist, which are briefly described below, together with the approximate voltage or current wave shape.

Line-commutated converters (LCC)

Line-commutated converters (LCC) are based on thyristor converters (see Figure 1401). They are characterized by a single direction of current flow, and a voltage polarity reversal possibility. Significant voltage and current harmonics exist up to frequencies of about 3 kHz to 4 kHz.

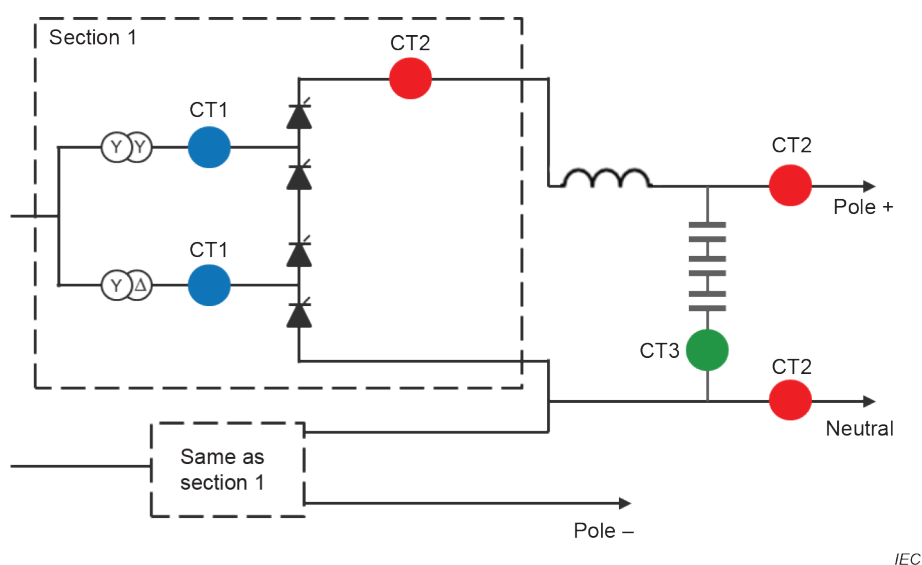

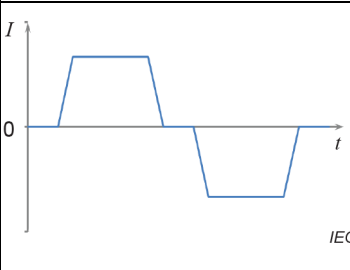
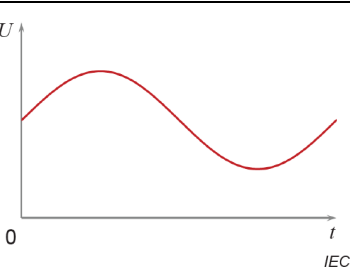
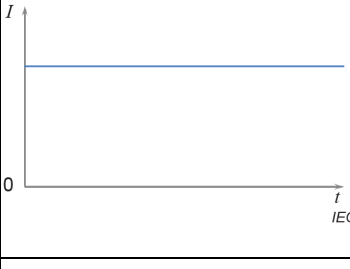
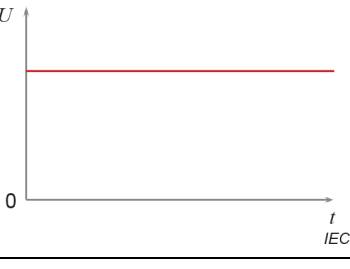
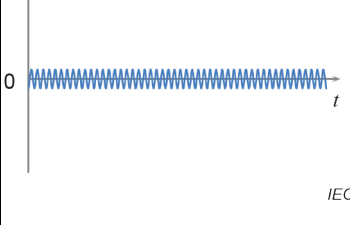

Figure 1401 – Example of LCC scheme

We distinguish three different current-measurement functions:

- CT1: measurement of the current at the AC side of the converter;
- CT2: measurement of the current at the DC side of the converter;
- CT3: measurement of the current in the DC filter.

Table 1401 gives an overview of the current and voltage waveshapes as well as the main characteristics of the different applications of the CT.

Table 1401 – Current and voltage in current transformers for LCC application

	Current	Voltage	Characteristics
CT1			AC current AC + DC voltage Large amount of current harmonics Mainly for protection purposes
CT2			Pure DC application High-accuracy measurement Harmonics measurement Metering, control and protection purposes
CT3			DC voltage stress with harmonics DC current = 0 Harmonics measurement Mainly for protection purposes

Voltage-source converters (VSC)

Voltage-source converters (VSC) are based on transistor converters. They are characterized by a bi-directional current flow and a single voltage polarity. Voltage and current harmonics exist up to frequencies of about 20 kHz.

Two variants of VSC schemes exist: symmetrical monopoles (using one single converter) and asymmetrical monopole or bipole (with one converter for each polarity).

Both schemes are shown in Figure 1402 and Figure 1403.

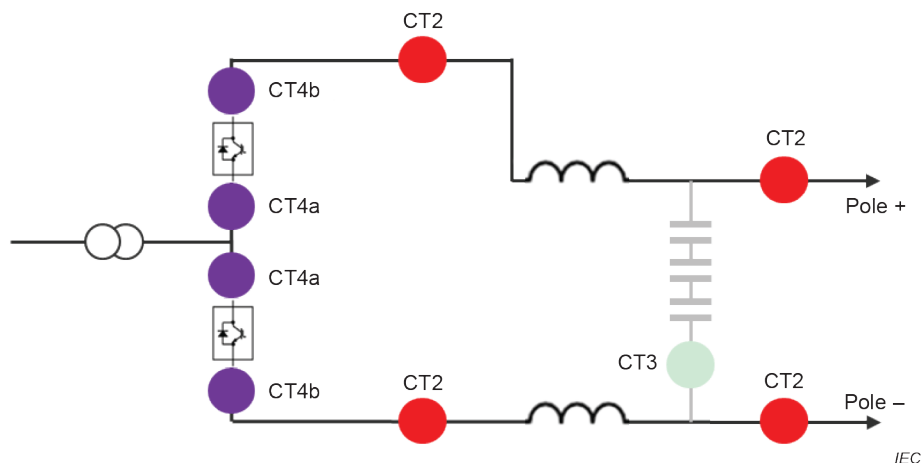
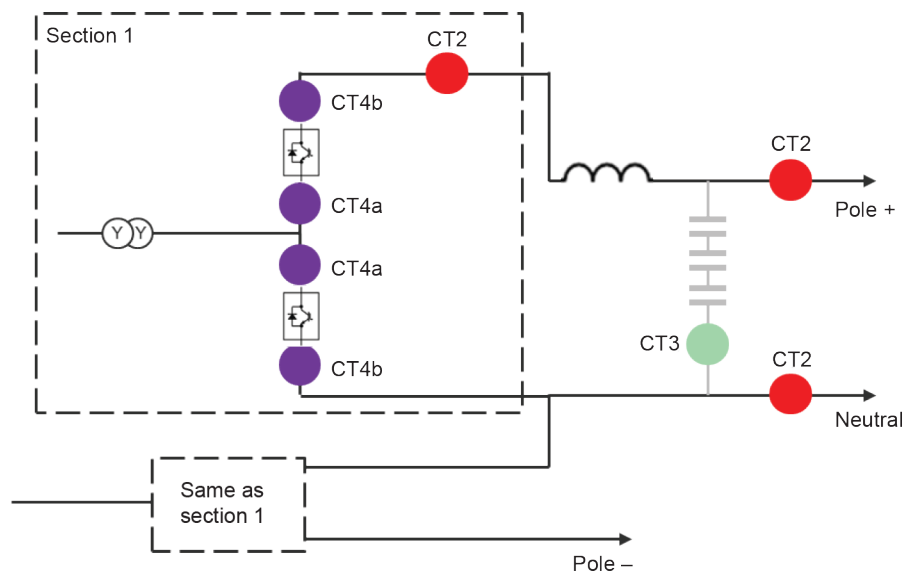

Figure 1402 – Typical scheme for VSC – symmetrical monopole



IEC

Figure 1403 – Typical scheme for VSC – asymmetrical monopole or bipole

We distinguish three different current-measurement functions:

- CT4: measurement of the current in the transistor branches of the converter.
The CT can be placed before (CT4a) or after the transistor branch (CT4b);
- CT2: measurement of the current at the DC side of the converter;
- CT3: measurement of the current in the DC filter (not always present in this scheme).

Table 1402 gives an overview of the current and voltage waveshapes as well as the main characteristics of the different applications of the CT.

Table 1402 – Current and voltage in current transformers for VSC application

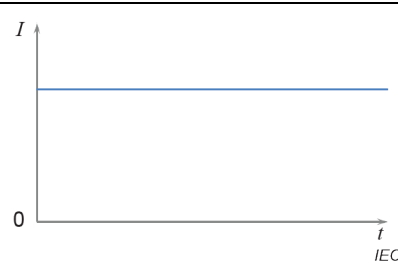
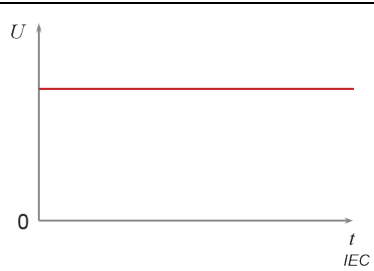
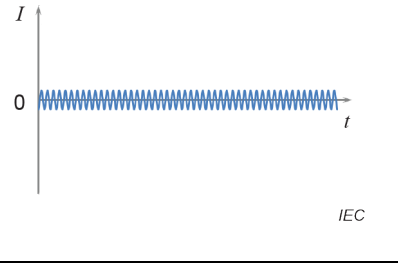
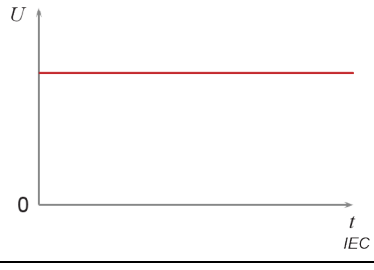
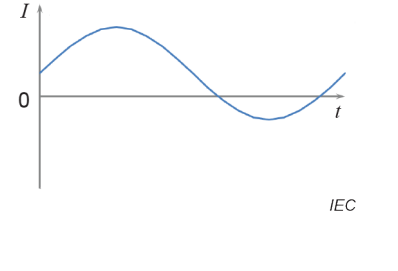
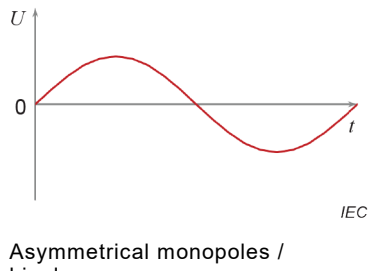
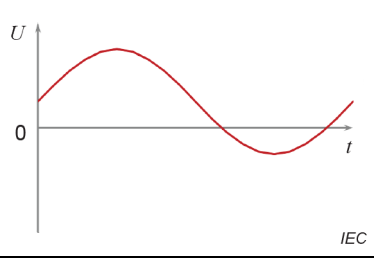
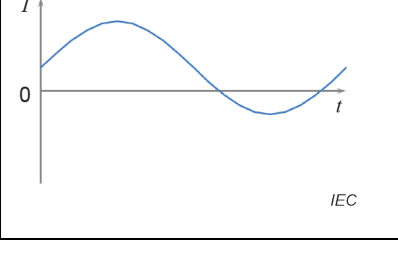
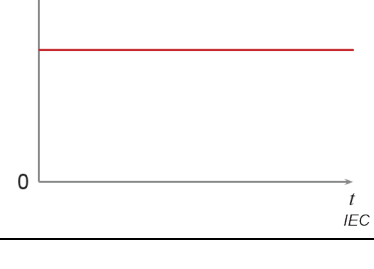
	Current	Voltage	Characteristics
CT2			Pure DC application High accuracy measurement Harmonics measurement Metering, control and protection purposes Short step response time
CT3			DC voltage stress DC current = 0 Harmonics measurement Mainly for protection purposes
CT4a		Symmetrical monopole:  Asymmetrical monopoles / bipoles: 	Pure AC voltage or DC + AC voltage DC + AC current High-accuracy measurement Short step response time
CT4b			DC voltage stress DC + AC current High-accuracy measurement Short step response time

INSTRUMENT TRANSFORMERS –

Part 14: Additional requirements for current transformers for DC applications

1 Scope

This part of IEC 61869 provides all requirements specific to current transformers to be used in DC applications (DCCTs), whatever the technology used. The output signal can be analogue or digital.

It is applicable to newly manufactured current transformers used for measuring, protection and/or control applications in DC power systems with a rated voltage above 1,5 kV.

The general configuration of a single-pole low-power instrument transformer is described in Figure 601 of IEC 61869-6:2016.

The DCCTs intended for current measurement in the transistor branch of the VSC valve (referred to as CT4a and CT4b in Figure 1403 and Table 1402) are not covered by this document, and will be considered in a future revision.

2 Normative references

The following documents are referred to in the text in such a way that some or all of their content constitutes requirements of this document. For dated references, only the edition cited applies. For undated references, the latest edition of the referenced document (including any amendments) applies.

Clause 2 of IEC 61869-6:2016 is applicable, with the following additions and modifications:

IEC TS 60815-4:2016, *Selection and dimensioning of high-voltage insulators intended for use in polluted conditions – Part 4: Insulators for DC systems*

IEC TS 61245:2015, *Artificial pollution tests on high-voltage ceramic and glass insulators to be used on DC systems*

IEC 61869-6:2016, *Instrument transformers – Part 6: Additional general requirements for low-power instrument transformers*

IEC 61869-9:2016, *Instrument transformers – Part 9: Digital interface for instrument transformers*

3 Terms and definitions

Clause 3 of IEC 61869-1:2007, of IEC 61869-6:2016 and of IEC 61869-9:2016 are applicable with the following additions and modifications.